

# Electronic Phase Delays

---

- A First Step Towards A Bench-Top Model of LISA -



James Ira Thorpe

Rachel Parks, Shannon Sankar, Rodrigo Delgadillo, Derek Mulder, Guido Mueller

University of Florida

---

5<sup>th</sup> International LISA Symposium – ESA ESTEC

Noordwijk, Netherlands

July 13<sup>th</sup>, 2004



# Overview



## Current Work

- What is Electronic Phase Delay (EPD)?
- Using EPD to make a “Synthetic Interferometer”

## Future Work

- Upcoming experiments
- The bench-top LISA model



# Introduction I - A Simple Model of A Single LISA Arm



- Laser field

$$E(t) = E_0 \exp\{i[\omega t + \phi(t)]\}$$

- Phase Meter (PM) Signal

$$S(t) \propto \phi(t) - \phi(t - \tau_{RT})$$

$\tau_{RT}$  5 round-trip light  
travel time

- Simplifying Assumptions

- far S/C acts as perfect optical transponder (mirror)
- stationary S/C (no Doppler shifts)

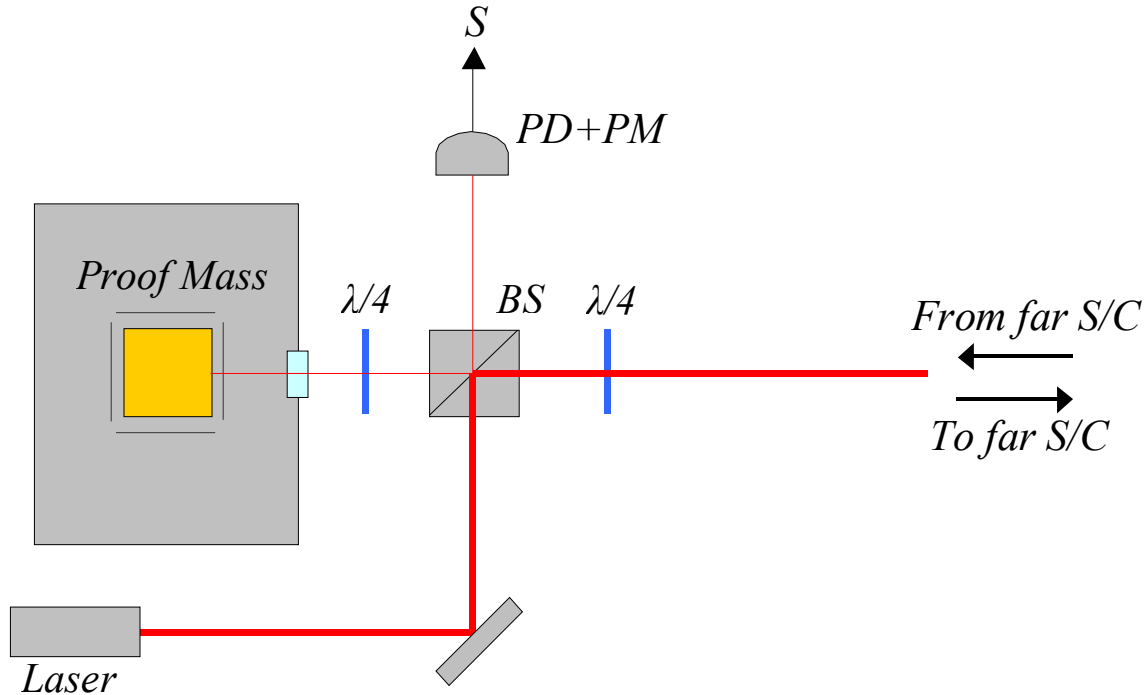



# Introduction II - The Problem



The large Optical Path Lengths (OPLs) in LISA correspond to  $\tau_{RT} \sim 33\text{s}$ .  
It is virtually impossible to create physical OPLs of this size in the laboratory.

**Solution:** We only need to delay the *phase* of the laser.

- demodulate it with a stable oscillator (another laser)
- digitize the difference phase
- store it in a buffer
- regenerate the signal

} Electronic Phase Delay (EPD)



# Implementation of Electronic Phase Delay (EPD)

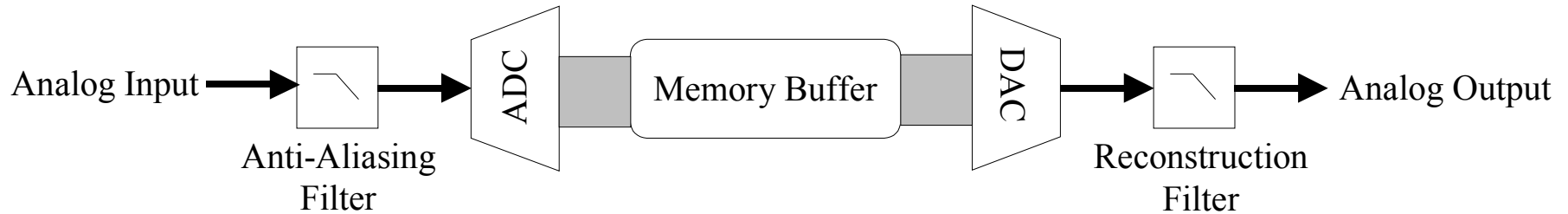

## Three Steps

- Digitize input signal
- Store in a FIFO memory buffer for the desired time.
- Regenerate analog signal

## Limitations

- Digitization Rate (limits bandwidth)
- Digitization Precision (noise)

## Current Iteration

- MicroStar DAP5216a Data Processing Card
- 200kS/s
- 16-bit
- signals ♥ 30kHz are reproduced well

## Future Technologies

- Increase digitization rate so that signals up to 20MHz can be delayed.



# Using EPD to Make a Synthetic Interferometer

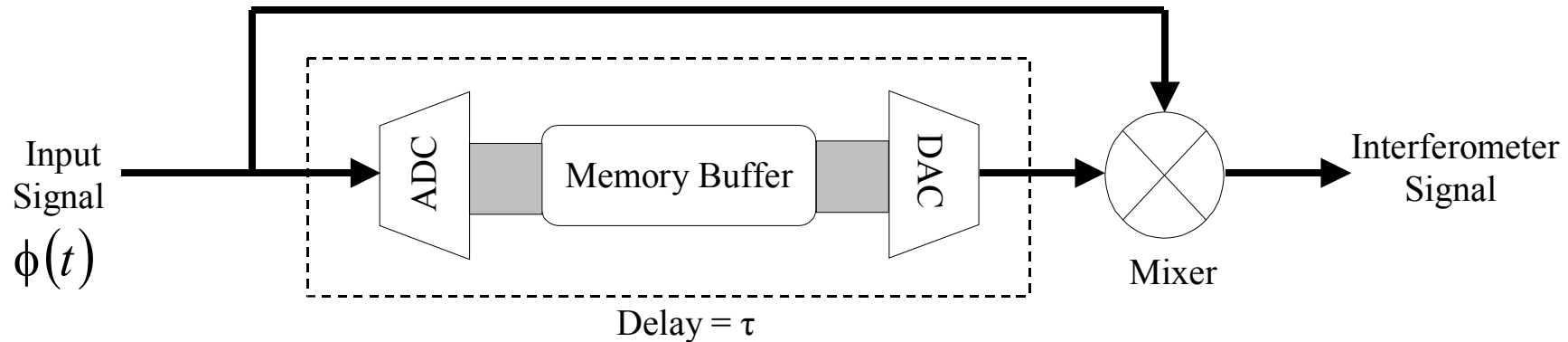

$$\text{Mixer Output, } S \propto \phi(t) - \phi(t - \tau)$$

Equivalent to an interferometer with  
one long arm having a delay of  $\tau$



# Demonstration of a Synthetic Interferometer

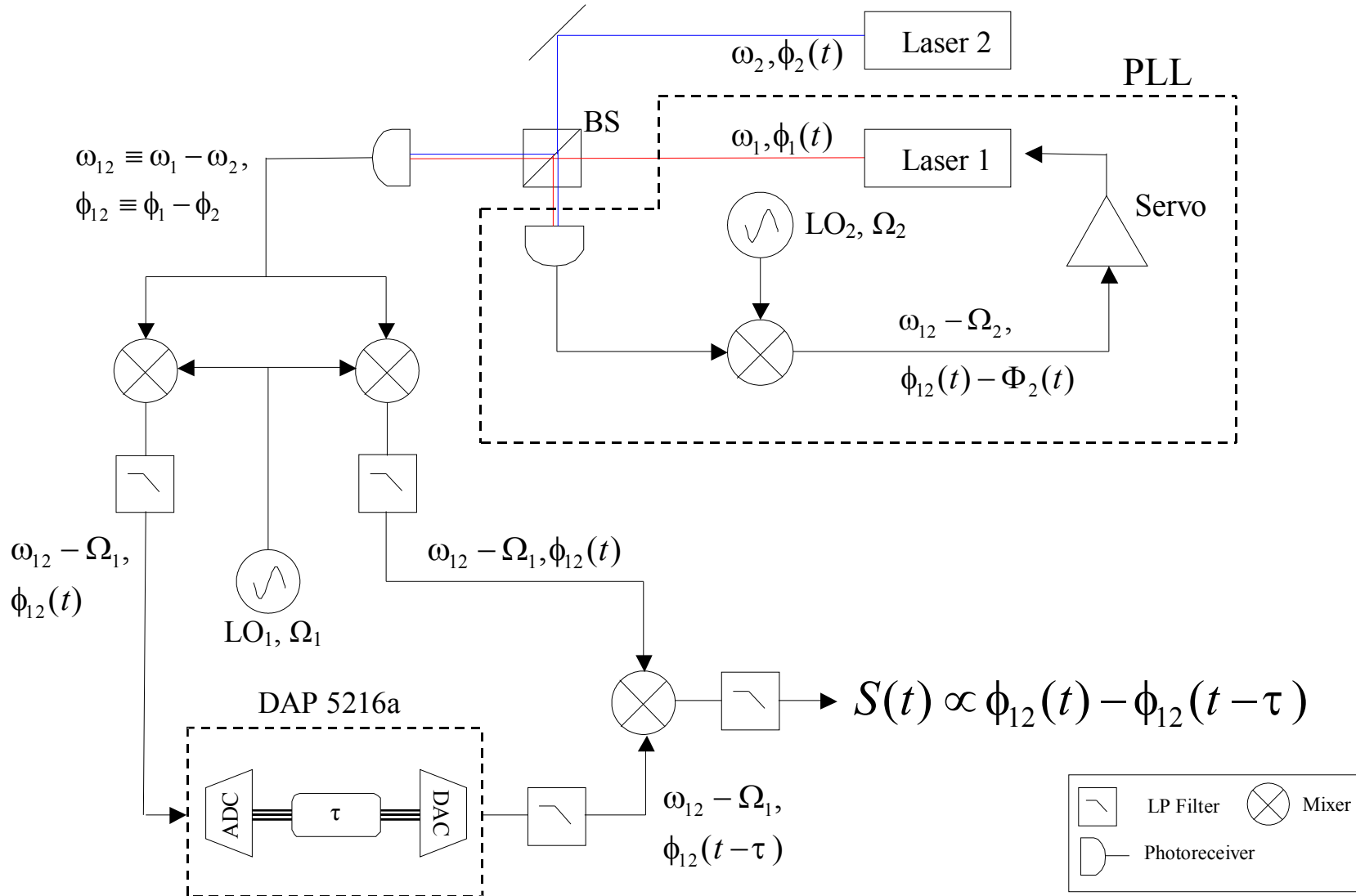



# Response To Frequency Step



- Time delay

$$\tau = 5s$$

- Step change of 1Hz on Laser 1  
(Achieved by stepping LO<sub>2</sub>)

- Observed Response

1Hz oscillation lasting for 5s.

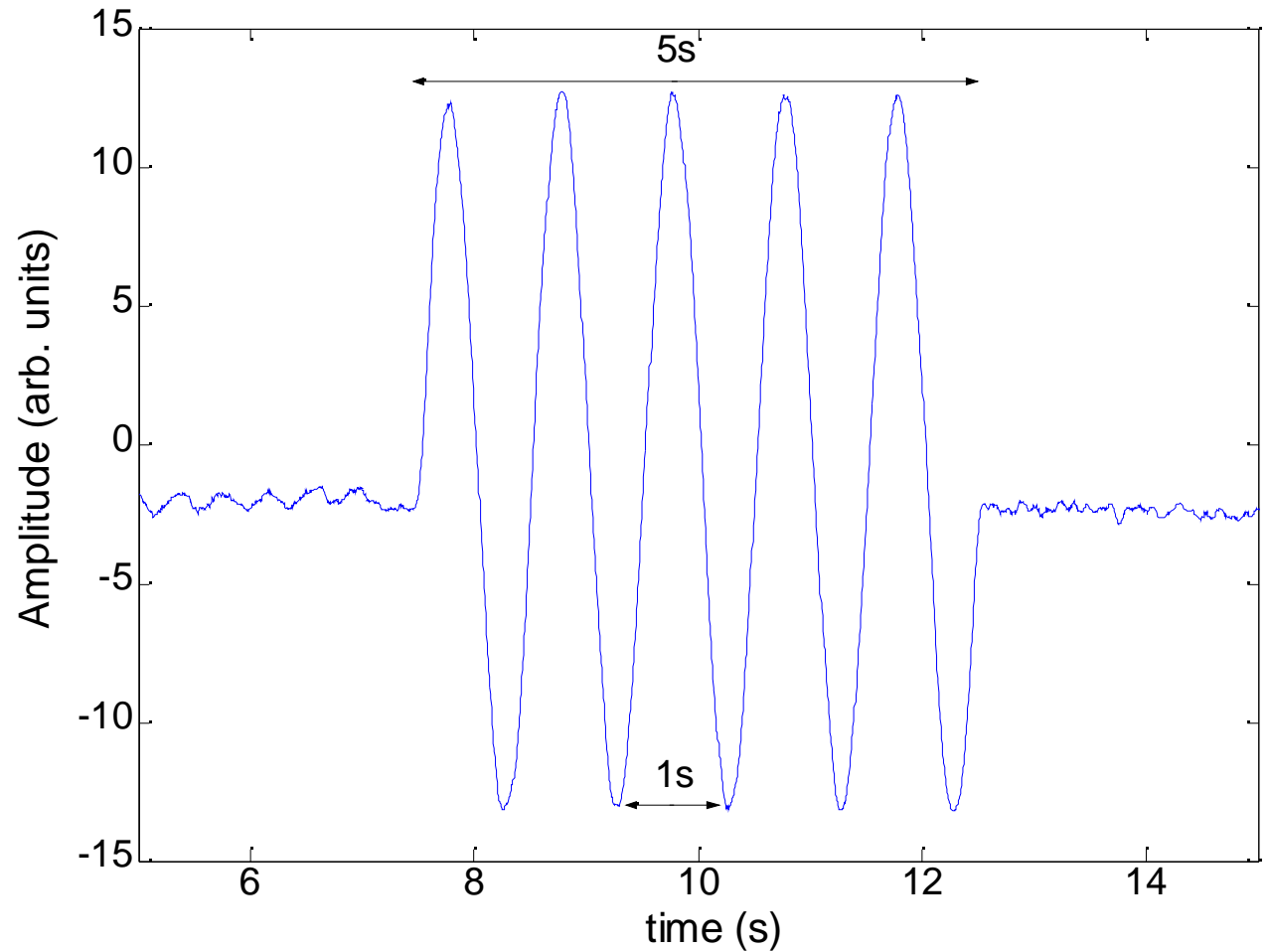



# Frequency Response



- Time delay

$$\tau = 1s$$

- Frequency Ramp on Laser 1

(by modulating  $LO_2$ )

$$\Omega_2 = 2\pi(20.03MHz + \Delta f)$$

$$\Delta f = (100mHz/s) \times t$$

- Observed Response

Sinusoidal amplitude variations with a frequency spacing of  $1/\tau = 1Hz$

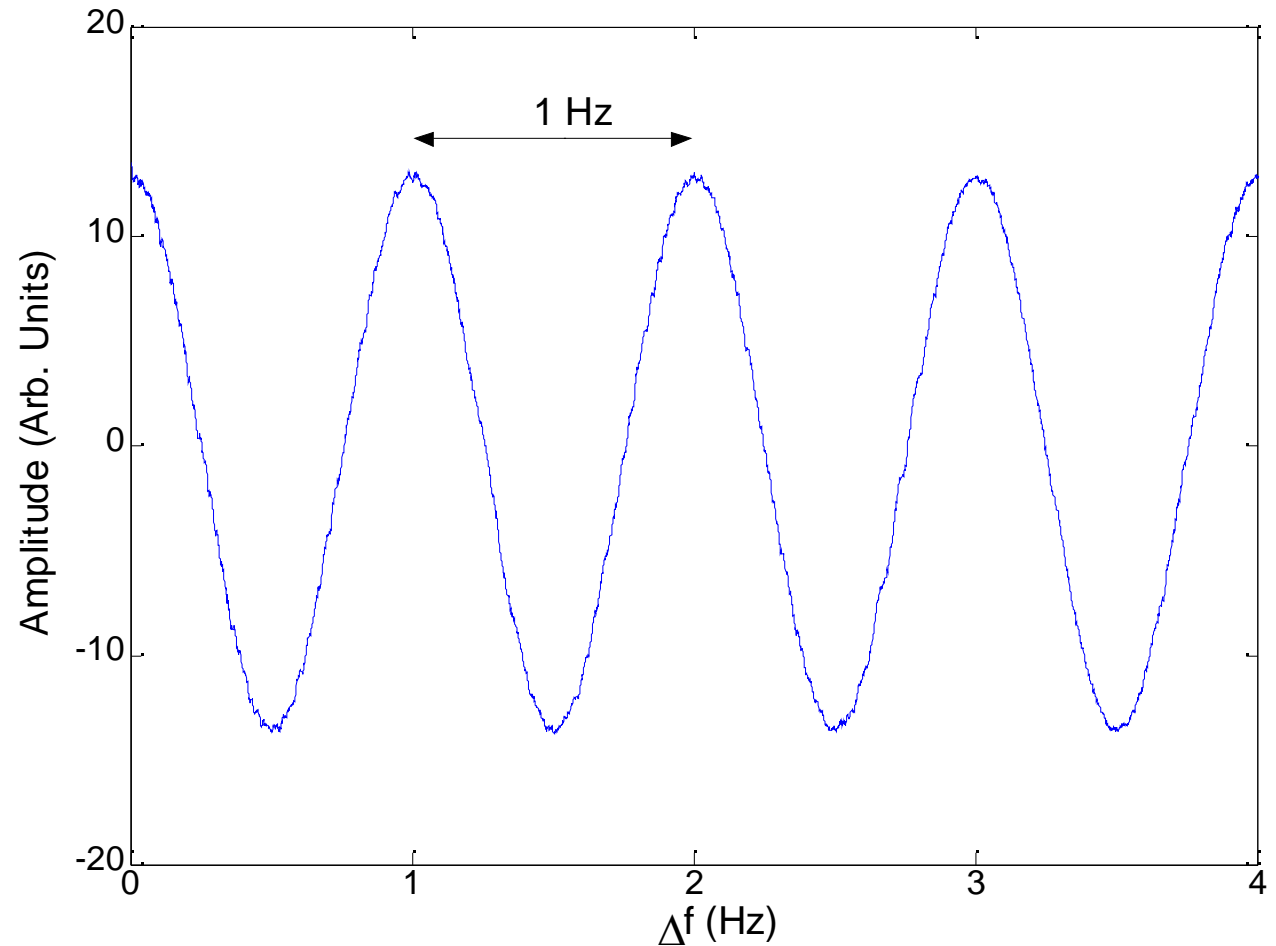



# Response to Phase Modulation I - Theory



- Mixer Output

$$S(t) \propto \phi_{12}(t) - \phi_{12}(t - \tau)$$

- Fourier Transform

$$\tilde{S}(2\pi f) \propto \tilde{\phi}_{12}(2\pi f)(1 - e^{-i2\pi f\tau})$$

- Transfer Function

$$T_{PM}(2\pi f) \equiv \frac{\tilde{S}(2\pi f)}{\tilde{\phi}(2\pi f)} \propto (1 - e^{-i2\pi f\tau})$$

$$|T_{PM}(2\pi f)| \propto |\sin(\pi f\tau)|$$

$$\angle T_{PM}(2\pi f) = \tan^{-1}[\cot(\pi f\tau)]$$

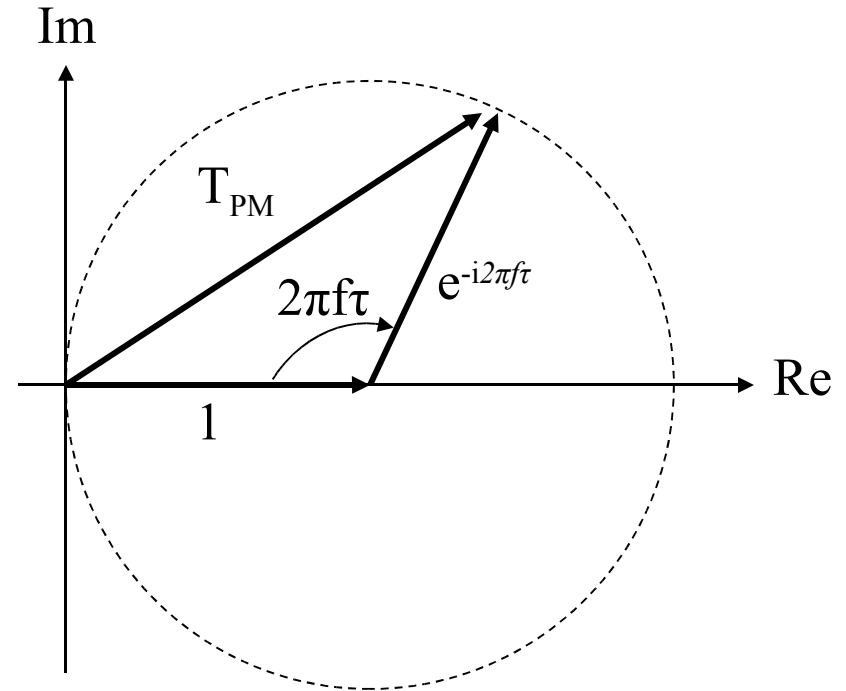

Zeros at  $f_0 \oplus n / \tau$

Phase Discontinuity  
from  $-90^\circ$  to  $+90^\circ$  at  $f_0$



# Response to Phase Modulation II - Results



- Time delay

$$\tau = 1s$$

- PM on Laser 1

- Sinusoidal at a frequency of  $f_{PM}$  with a modulation depth of  $20^\circ$ .

- Observed Response

- No response at  $f_{PM} = n/\tau$ ,  
 $n = 1, 2, 3 \dots$

- $180^\circ$  phase discontinuity at  $f_{PM} = n/\tau$

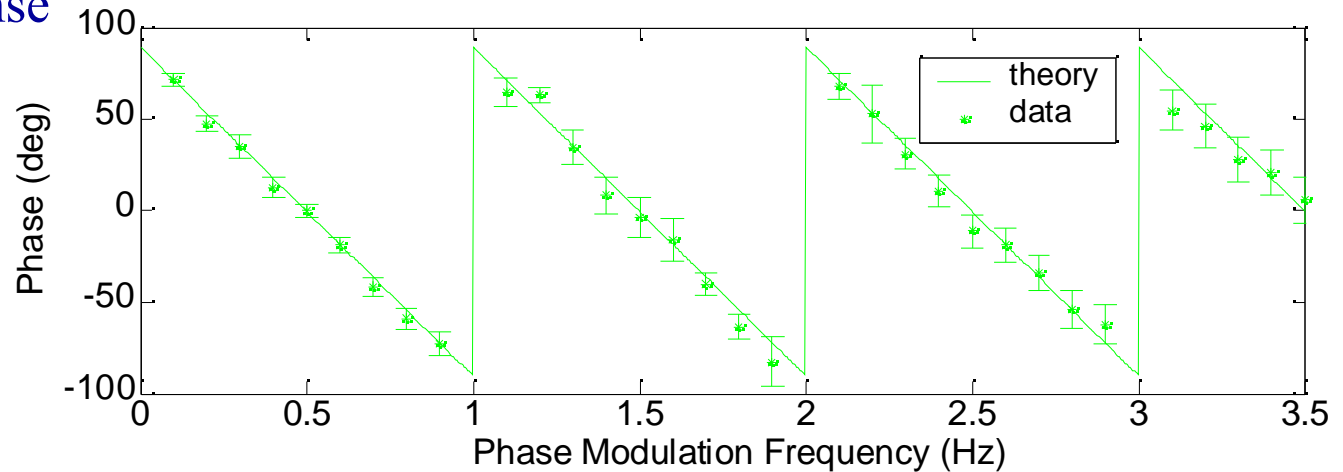
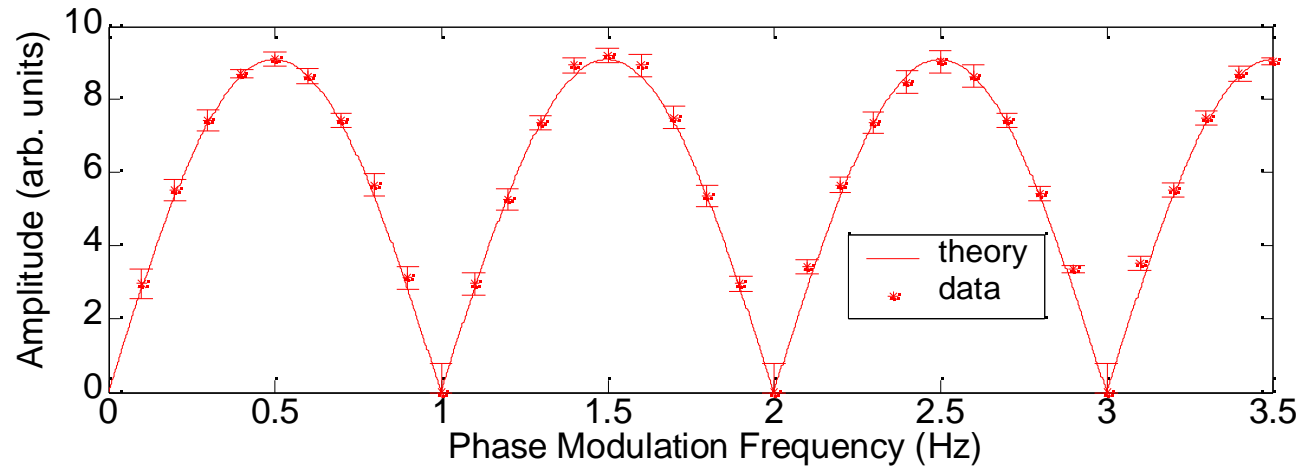



# The Next Step I – Arm Locking

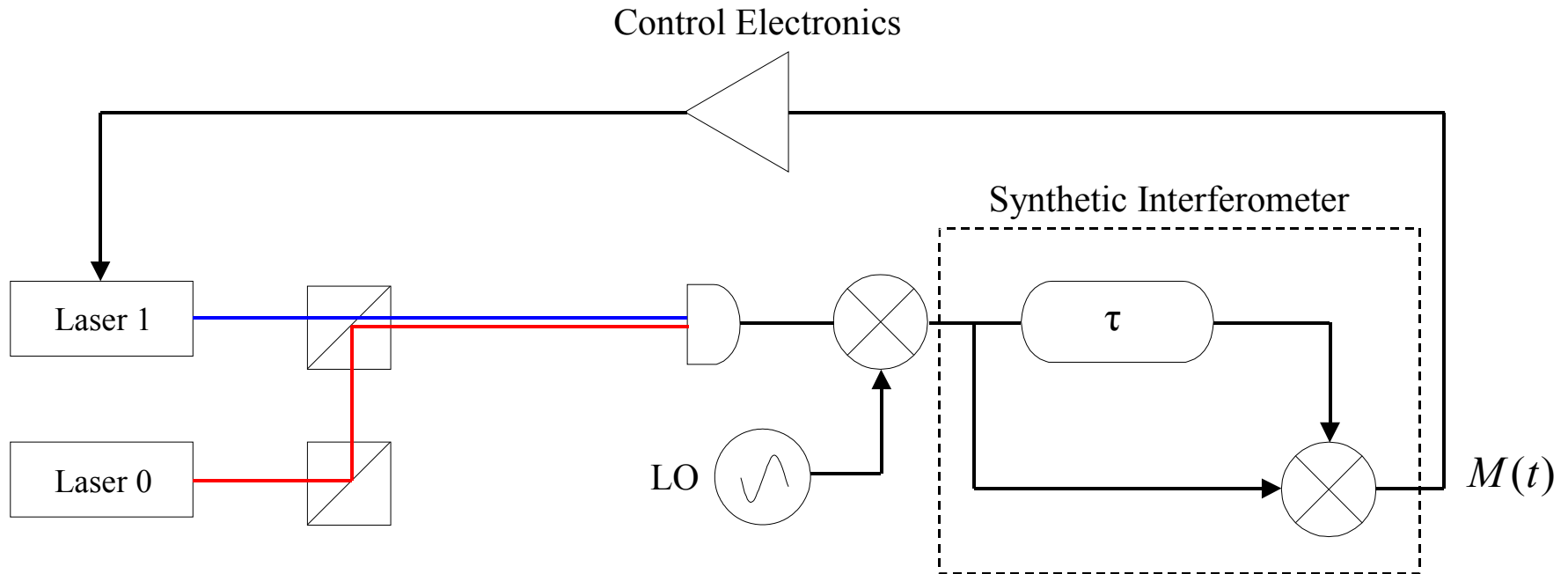

## Interferometer Signal

$$M(t) \propto \phi_{10}(t) - \phi_{10}(t - \tau)$$

Lock laser phase difference to interferometer zero

$$\phi_{10}(t) = \phi_{10}(t - \tau)$$



# The Next Step II – “TDI” With a Single LISA Arm

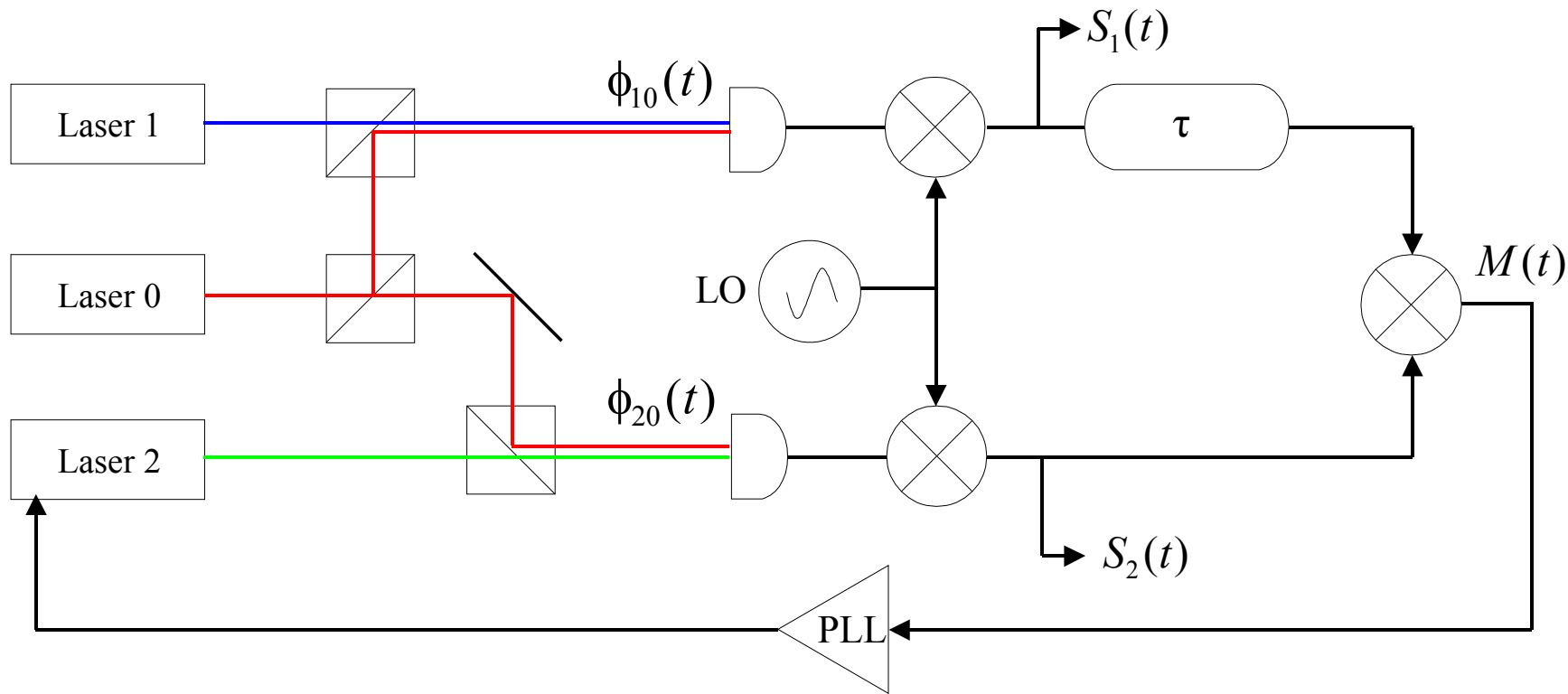

Phase Lock  $M(t) = 0 \Rightarrow \phi_{20}(t) = \phi_{10}(t - \tau)$

Experimental Test  $\angle S_2(t) = \phi_{20}(t) \stackrel{?}{=} \angle S_1(t - \tau) = \phi_{10}(t - \tau)$



# The Next Step III – TDI with Two Arms

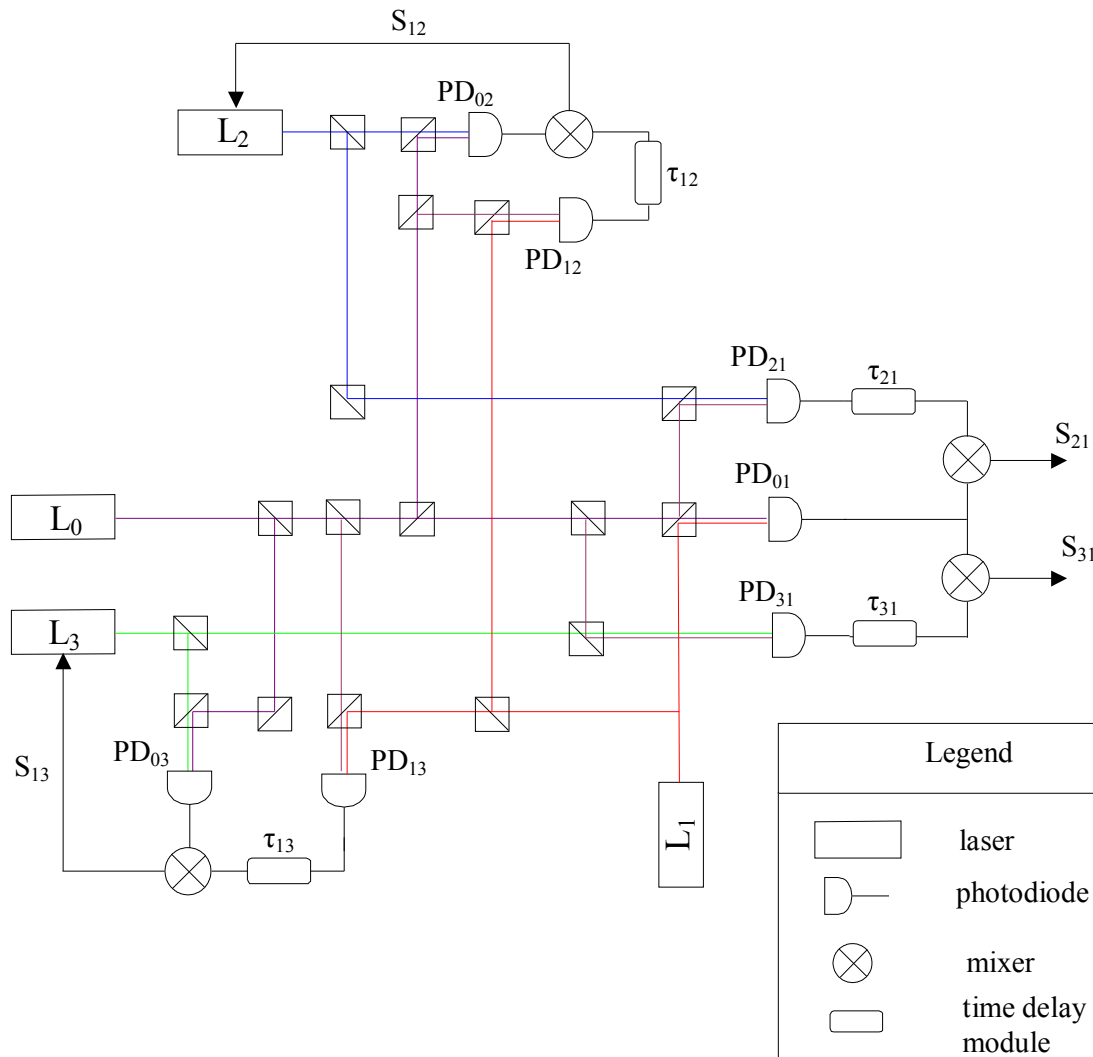

Interferometry Signals on S/C 1

$$S_{21}(t) \text{ \& } S_{31}(t)$$

Experimental Test of TDI

$$\begin{aligned}
 & S_{21}(t) - S_{21}(t - \tau_{13} - \tau_{31}) \\
 & - S_{31}(t) + S_{31}(t - \tau_{12} - \tau_{21}) \\
 & = 0?
 \end{aligned}$$



# Long Term – Getting to a model LISA



- Incorporate additional features
  - clock noise
  - Doppler shifts
  - bench motion

- Add 3<sup>rd</sup> arm
- Add GW signals
- Incorporate data reduction algorithms
- ...?

*Take it for a test drive!*

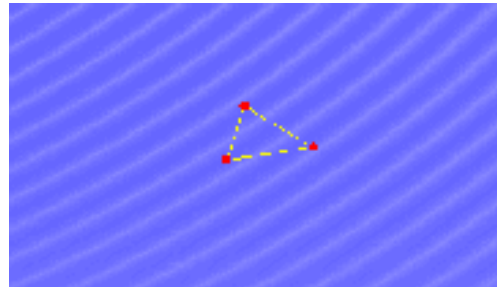

Host a “Mock Data Challenge” in which we inject a GW signal and then attempt to extract it.



# Thanks/Questions



The LISA crew at UFL

(front row, left to right) Ira Thorpe, Shannon Sankar, Rodrigo Delgadillo, Derek Mulder (standing) Rachel Parks, Guido Mueller



# Frequency Response - 2



- Time delay

$$\tau = 5s$$

- FM on Laser 1

(by modulating  $LO_2$ )

$$\Omega_2 = 2\pi(20.03MHz + \Delta f)$$

$$\Delta f = (100mHz/s) \times t$$

