

# PLANCK



Planck is the European Space Agency's mission to map the structure of the Cosmic Microwave Background in unprecedented detail. Planck will observe the Universe as it was 300000 years after the Big Bang, will constrain cosmological models and examine the birth of large-scale structure in the Universe.

## Mission Overview

The third medium-sized (M3) mission of ESA's Horizon 2000 programme, Planck will measure temperature fluctuations in the **Cosmic Microwave Background (CMB)** with a precision of  $\sim 2$  parts per million, and an angular resolution of better than  $\sim 10$  arcminutes.

### Mission prescription:

- Offset telescope with an aperture of 1.5 m
- Detectors with state of the art sensitivity
- Very wide frequency coverage to remove foregrounds
- Extreme attention to suppression of systematic effects

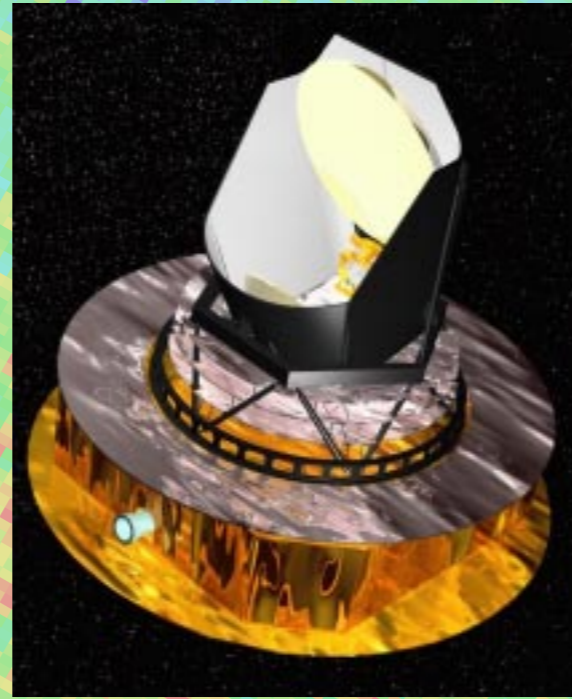

### Payload Complement:

- **Low Frequency Instrument** (30-100 GHz tuned radio receiver arrays operated at 20 K) provided by a consortium of institutes led by TeSRE-CNR (Bologna)
- **High Frequency Instrument** (100-850 GHz bolometer arrays operated at 0.1 K) provided by a consortium led by IAS (Orsay)
- Telescope **Reflector System** to be delivered by a consortium led by the DSRI (Copenhagen)

## Scientific Objectives

Planck will place fundamental constraints on models of the birth and evolution of the Universe

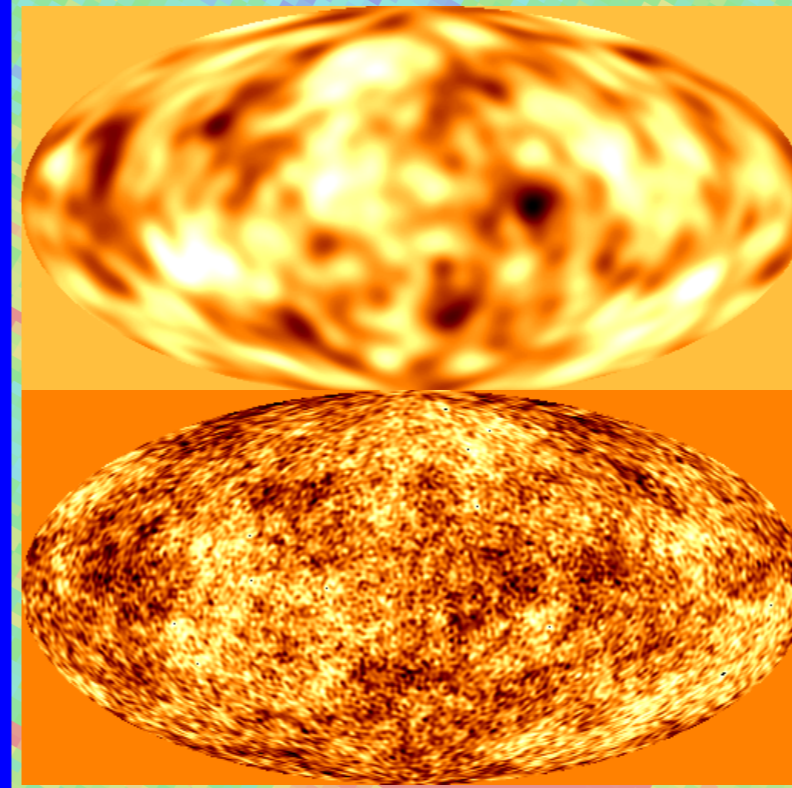

A comparison between simulated CMB maps (based on a cold dark matter inflationary scenario) as would be seen by **COBE** (above) and **Planck** (below), illustrate the improvement in the knowledge of the CMB to be obtained by Planck. Such measurements will be used to construct angular power spectra of the temperature fluctuations of the CMB.

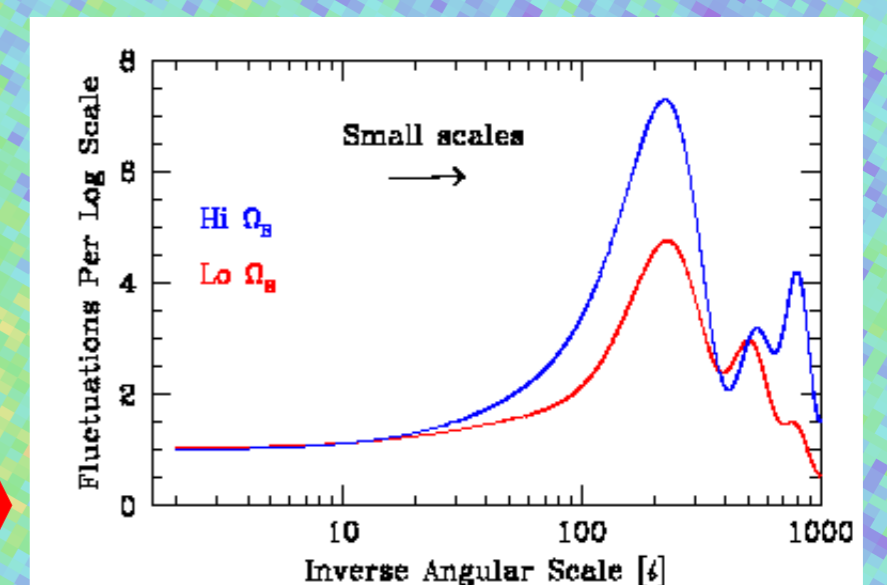

Values of **cosmological parameters** can be determined to high accuracy by comparing model and observed temperature power spectra. As an example, the predicted influence of the density parameter ( $\Omega$ ) on the power spectrum is shown here.

## Technical Overview

### Main technical drivers:

- **Optical:** very wide field of view ( $\sim 8^\circ$ ), low-aberration and low-spillover telescope/detector combination
- **Thermal:** cryogenic cooling sequence: passive radiators (to 60 K), sorption cooler (to 20 K), Joule-Thomson stage (to 4 K), dilution stage (to 0.1 K)
- **Straylight:** rejection of Sun radiation at detector level must be of order 100 dB, and of other planets and galactic emission  $\sim 60$  dB

### Main operational elements:

- Launch via **Ariane V** vehicle - six month transfer time to final orbit
- Orbit around the second Lagrangian point of the Sun-Earth-Moon system (L2)
- Spin-stabilized at **1 rpm** (spin axis vertical in this diagram)
- Optical field of view offset by  $80^\circ$  from spin axis, sweeps a large circle on the sky every minute
- Spin axis maintained in the anti-Sun direction to cover the **full sky in  $\sim 7$  months**

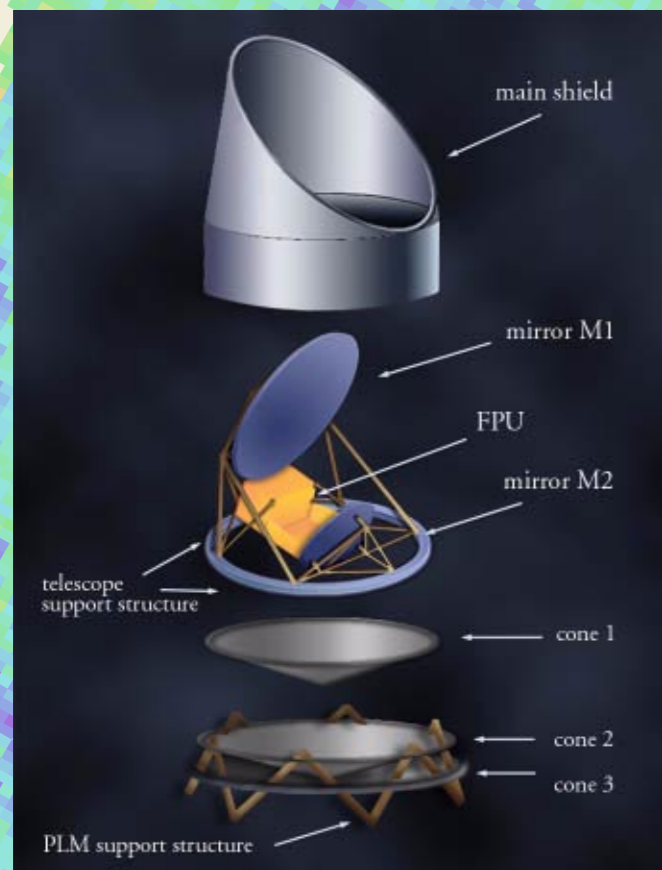

## Scientific Features

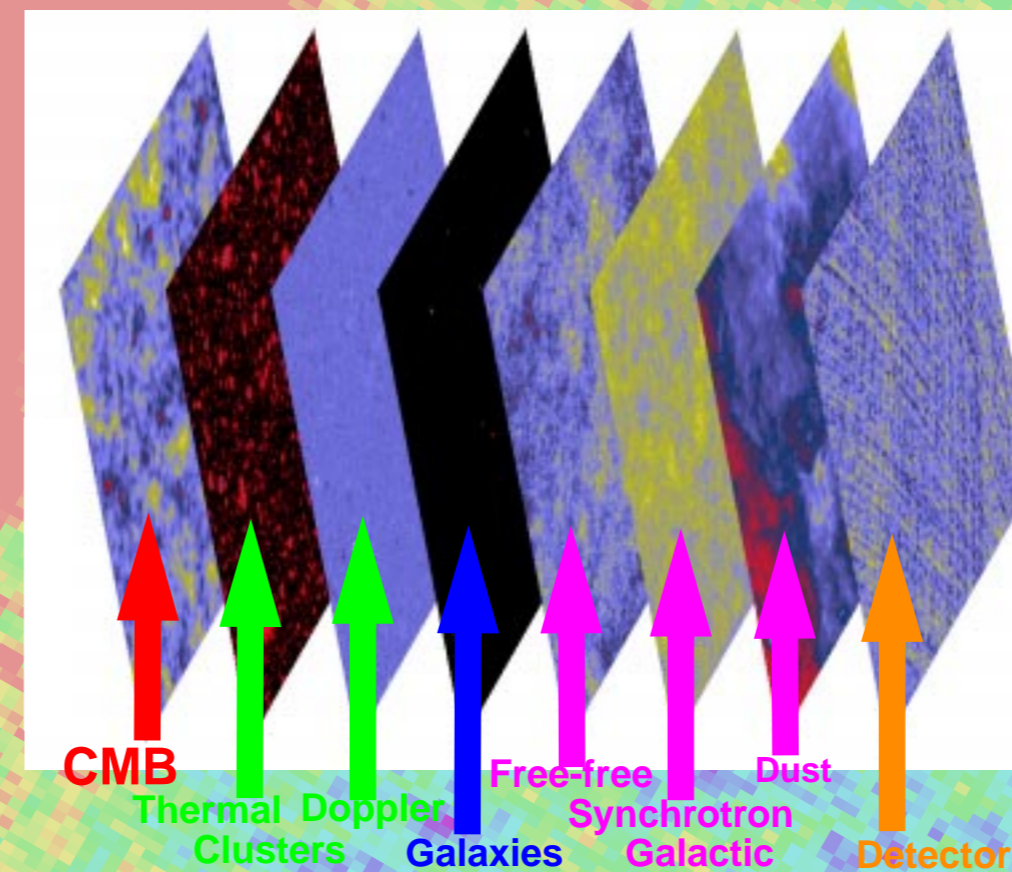

In order to map the anisotropies of the Cosmic Microwave Background, Planck's observations must first be corrected for the effects of detector noise and of many layers of intervening **foregrounds** (both of galactic and extragalactic origin).

Therefore, as a "by-product", Planck's observations will provide a wealth of information about our own **Milky Way** and **other galaxies**. One notable product will be measurements of the Sunyaev-Zeldovich signature in many hundreds of clusters of galaxies.

## Instruments

Planck carries **two instruments**, fed by a 1.5 m offset telescope:

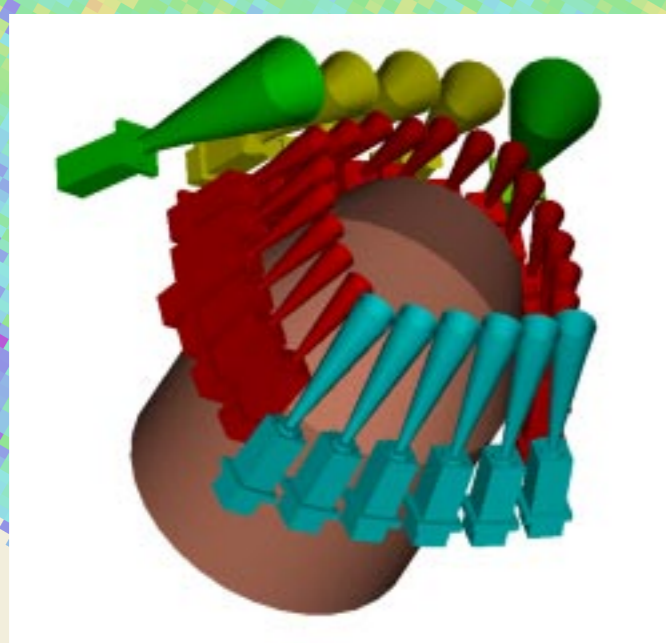

The **Low Frequency Instrument (LFI)**: consists of four arrays of 56 HEMT-based radio receivers, between **30 and 100 GHz**, fed by a ring of corrugated horns, and operated at a temperature of  $\sim 20$  K. Best angular resolution  $\sim 10$  arcmins, best temperature sensitivity  $\sim 12 \mu\text{K}$ . The LFI is inserted in the center of the LFI (brown insert in diagram). The LFI is provided by a consortium of institutes led by N. Mandolesi (Istituto TeSRE-CNR, Bologna, Italy).

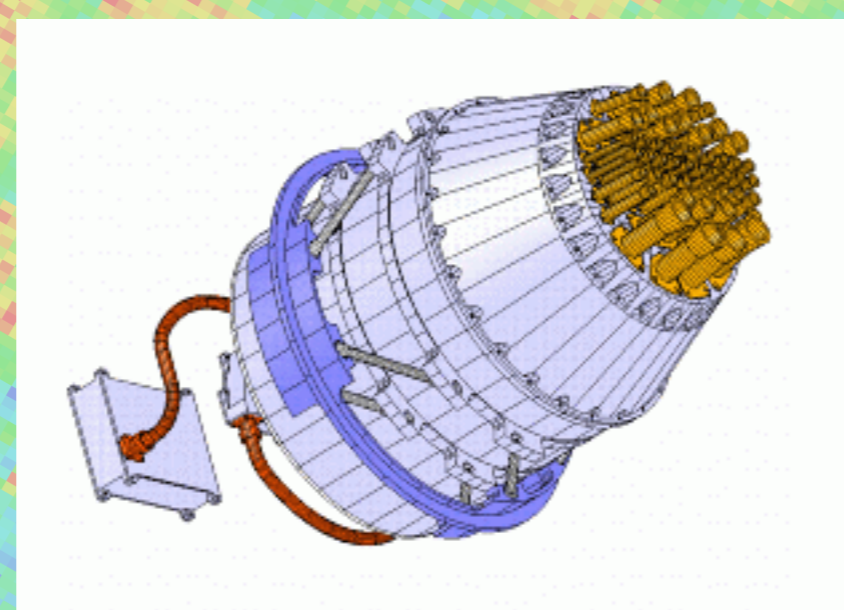

The **High Frequency Instrument (HFI)**: consists of six arrays of bolometers, between **100 and 850 GHz**, fed by corrugated horns and filters occupying the center of the focal plane, and operated at  $\sim 0.1$  K. Best angular resolution  $\sim 5$  arcmins, best temperature sensitivity  $\sim 5 \mu\text{K}$ . The HFI is provided by a consortium of institutes led by J.L. Puget (Institut d'Astrophysique Spatiale, Orsay, France).

## Mission status

Since Planck will be placed in a similar orbit to that of **FIRST** (ESA's Far Infrared and Submillimetre Telescope), both will be launched by the same Ariane V rocket, in the so-called "**Carrier**" configuration. In this setup, FIRST is supported by Planck within the Ariane fairing, they separate shortly after launch, and transfer to orbit independently.

Planck and FIRST will be **launched** in the first quarter of **2007**.

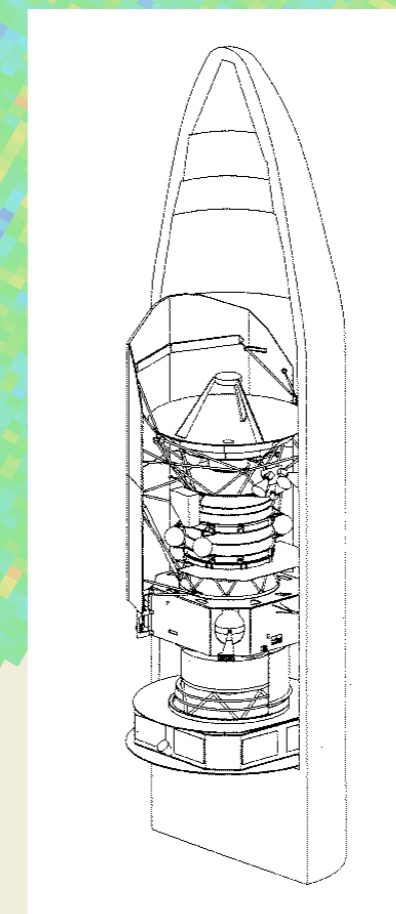

**FIRST**

**Planck**

